

Resi-Ply™

FORMING SYSTEM



 **SYMONS**
BY DAYTON SUPERIOR

Resi-Ply™ System

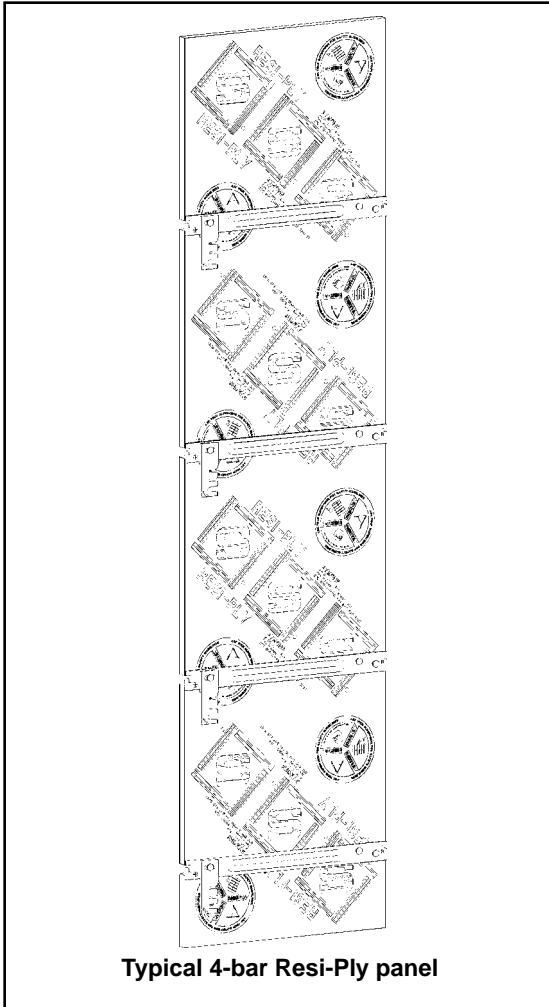

The Resi-Ply forming system is a 1½" thick plywood with steel backing bars designed especially for residential foundations and low industrial concrete walls.

The Resi-Ply system can be positioned and set quickly. Each form has attached hardware that secures the ties and adjacent form. This connection also helps align the formwork. Waler Brackets slide over the bolts to secure the lumber and bring formwork into alignment.

Resi-Ply panels, fillers, ties and other components are interchangeable with other 1½" plywood forming systems, so there's no need to obsolete your current system in order to switch to the Resi-Ply system.

- ◆ Durable, 1½" 100/100 HDO conforms to U.S. Product Standard PSI-83 for Structural I Plywood to provide consistent strength and quality.
- ◆ Attached locking hardware eliminates the extra costs associated with lost parts and speeds setting.
- ◆ Form heights from 2' to 10', with 4-bar, 5-bar and 6-bar configurations, provide extra versatility and compatibility.
- ◆ Relatively flat panel design takes up less space and leaves more room on the truck for other forming materials.
- ◆ Complete list of fillers and corners, with optional bar configurations, means no improvising or job-building.

Corners and Walers

Corners

Durable all-steel corners are available in heights from 2' through 10', in 1' increments. Additional reinforcement is used to strengthen and maintain true 90° corners, even after many uses.

Inside Corners are available in 4" x 4", 4" x 6", or 6" x 6" dimensions, for added versatility.

1" x 1" Outside Corners are manufactured with attached latches for easy and fast assembly.

Alternate 2" x 2" Outside Corners provide yet another way to form corners.

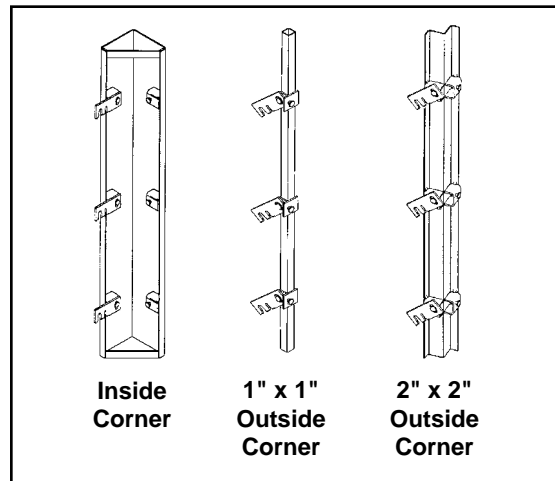

Walers

With modular forming, the strength of the panels make walers necessary for alignment only.

The Resi-Ply system requires only one row of walers for each tier of panels. Waler Brackets are available in nominal 6", 8", 10" and 12" sizes.

When attached to panels and fillers, the Waler Bracket provides quick and easy form alignment using conventional lumber.

The Top Waler Bracket is another waler option. Placed at top of the form with 2x4 lumber, it quickly aligns forms with a hammer blow to the wedge.

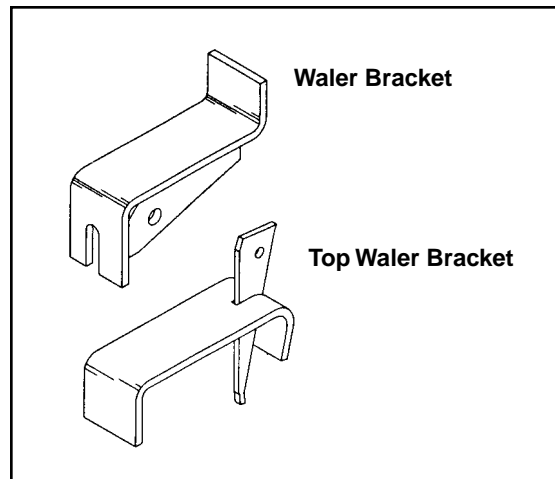

Line-up Rail

The Line-up Rail eliminates the need for lumber walers. The flared steel design allows easy installation along the top edge of forms for alignment.

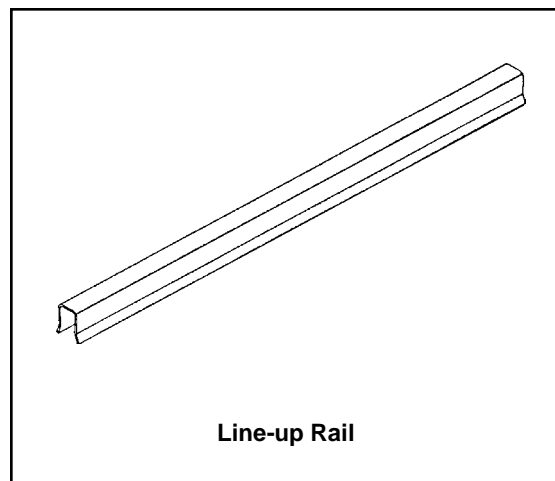

Ties and Hardware

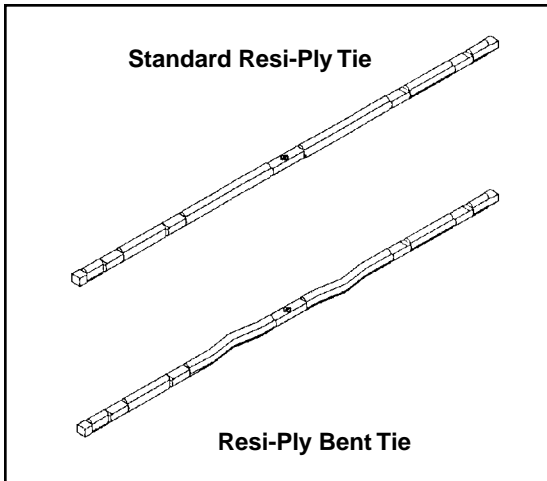

Ties

Resi-Ply™ ties are manufactured from high-quality steel and designed to break back cleanly at the concrete surface. Straight or bent ties are available in any length, with an ultimate capacity of 5000 lbs. A standard Break Off Tool is used to break tie ends for quick form stripping.

Scaffold Brackets

The Scaffold Bracket provides a safe working platform for concrete placing operations and meets established OSHA recommendations.

The Scaffold Bracket has four keyhole-shaped slots that fit over the shoulder bolts of the 4-bar, 5-bar or 6-bar system. It is designed with a clip angle for a 2" x 6" lumber waler.

Note: Scaffold Brackets are work platforms only and may not be used to support cantilevered soffit forms or materials.

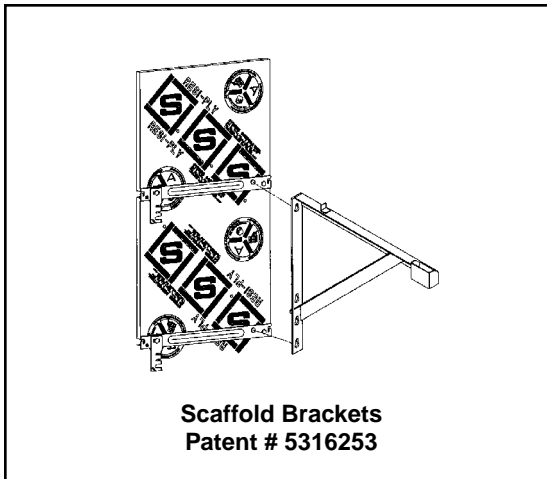

Resi-Ply Aligners

The Resi-Ply Form Aligner is designed with a latch plate on one end for attachment to the shoulder bolt of a panel. These aligners are easy to adjust and eliminate the waste of conventional lumber bracing.

Note: Form Aligners are only intended to plumb formwork, and are not to be used to resist concrete pressure or other loads.

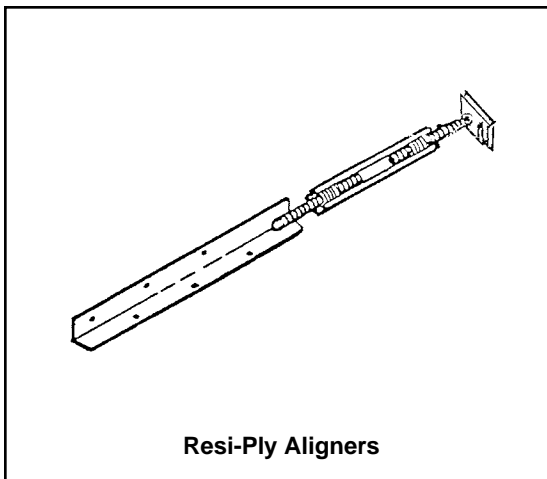

Hinged and Bay Corners

Hinged Corners

The Inside Hinged Corner form inside corners down to 45°, significantly reducing job-building costs for unusual corner configurations.

Hinged Corners come in either a 4" or 8" face to accommodate forming an outside corner.

Note: *Because of the inherent flexibility of hinges, corners should always be blocked and braced as needed.*

Inside Bay Corners

The fixed Inside Bay Corner is used opposite the 45° Bay Corner Clip to form an accurate 135° angle wall corner. The standard 4¾" x 4¾" face is used in combination with an 8" filler adjustment to the Bay Corner Clip when pouring an 8" wall. The attached latches quickly connect the adjacent panel or filler.

45° Bay Corner Clips

The 45° Bay Corner Clip used opposite of the Inside Bay Corner or the Inside Hinged Corner forms a 135° angle wall corner. Corner Clips are attached at bar locations adjusted to proper filler width and height. The 45° Bay Corner Clip provides accurate outside corners quickly and economically.

Outside Bay Corners

The Outside Bay Corner is used opposite of the Inside Bay Corner and forms a 135° angle wall. The attached latches quickly connect the adjacent panel or filler. Because it is manufactured as one piece, the steel Outside Bay Corner maintains its shape without backing.

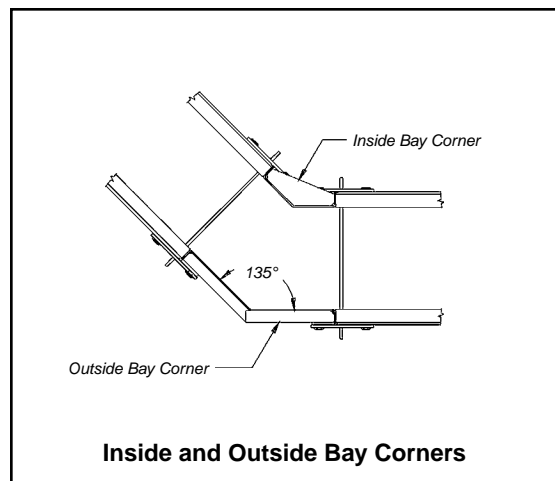
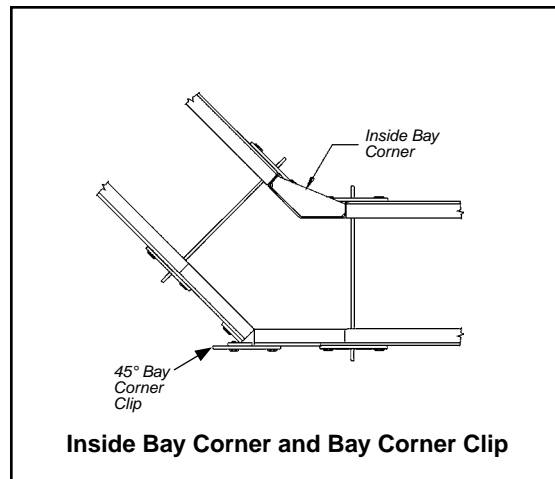
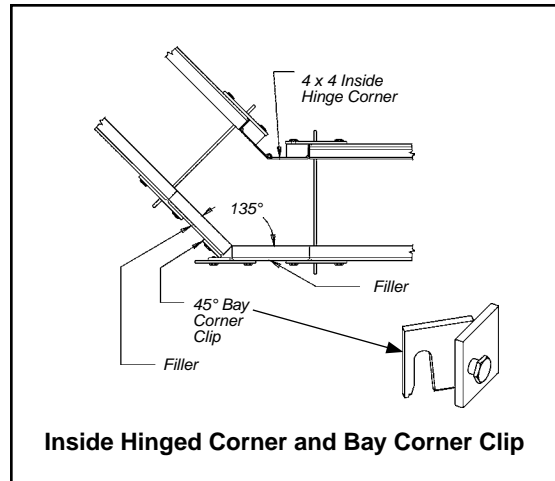

Special Forming Components

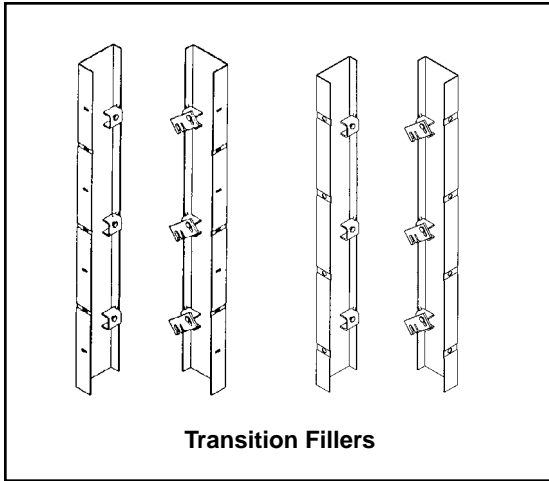

Transition Fillers

Transition Fillers help you quickly connect Resi-Ply™ to Steel-Ply® or Resi-Ply to Symons Silver™ for maximum inventory utilization of forming systems.

The Resi-Ply/Steel-Ply Transition Filler allows you to use Steel-Ply versatility for forming curved walls and to simplify complicated forming applications.

The Resi-Ply/Silver Transition Filler allows you to use existing forms for below grade walls and Symons Silver for exposed walls where concrete finish is important.

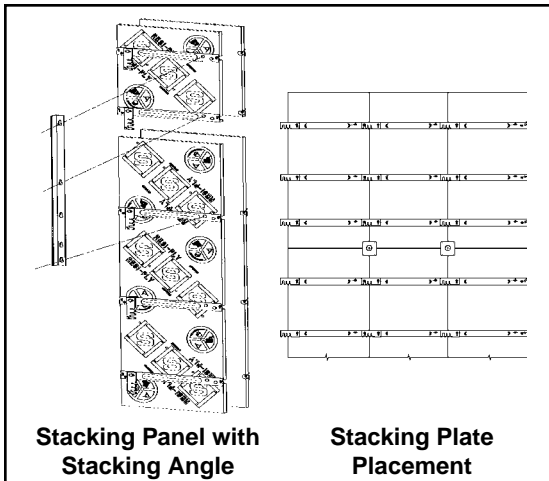

Stacking Panels

The Stacking Panel and Fillers are used to achieve an additional 2' form height. The Stacking Panel is designed with two cross bars, the bottom bar overlaps the top of the panel or filler below for additional strength.

Stacking Angles

The Resi-Ply Stacking Angle is designed as a strongback angle when used with a Stacking Panel.

The Stacking Angle has five keyhole-shaped slots that fit over the bolt heads of the bracing bars on the Stacking Panel and the top bar on the form below.

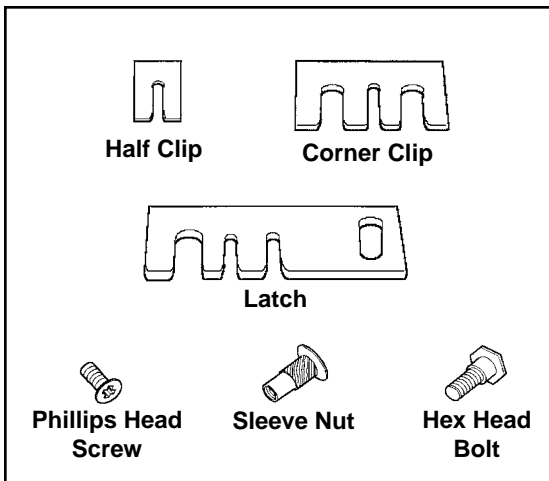

Stacking Plate

The Stacking Plate is used to align forms at the intersection between two panel heights. The center notch provides a tie placement to prevent misalignment of panels and fillers.

Half Clip and Corner Clips

Half Clips are used for forming against an existing wall, or where the panel or filler latch interferes with the forming application. Corner clips are used to secure inside and outside corners if corner latches are missing. Replacement of attached hardware is simple with hardware accessories.

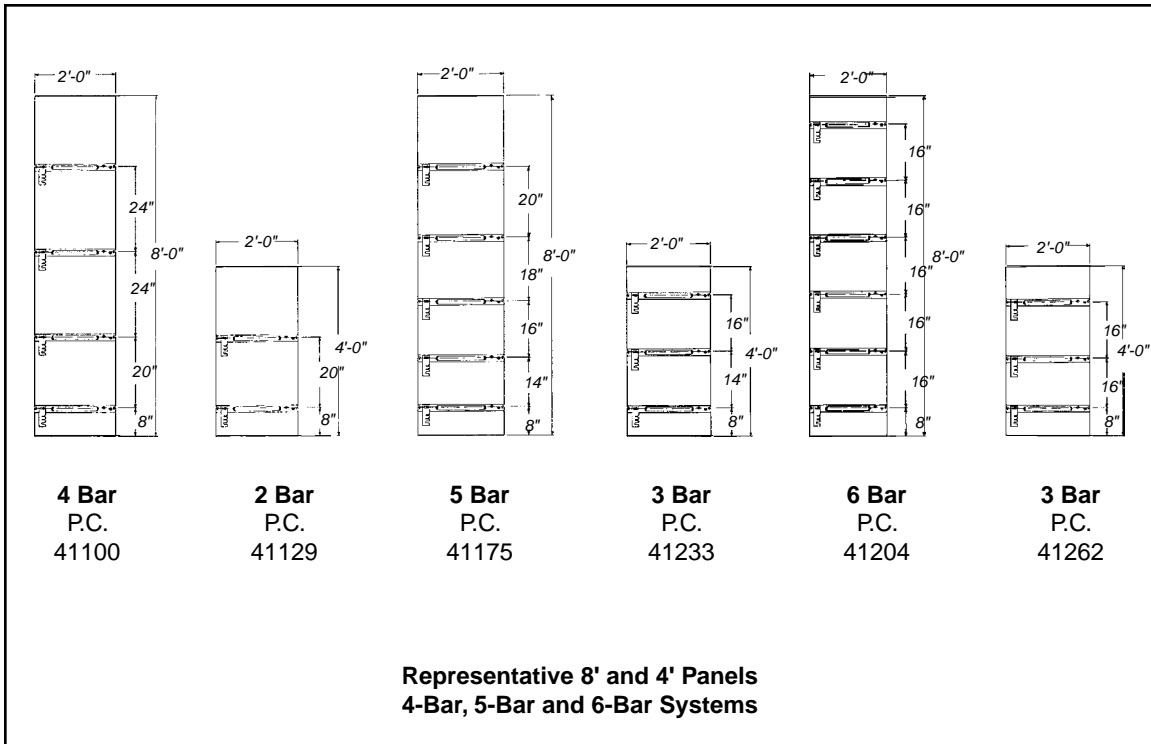

	Height of Panel	1st Bar up from Bottom	2nd Bar from 1st Bar	3rd Bar from 2nd Bar	4th Bar from 3rd Bar	5th Bar from 4th Bar	6th Bar from 5th Bar	7th Bar from 6th Bar	Top Bar from Top
4 Bar System	48"	8"	20"	—	—	—	—	—	20"
	60"	8"	20"	24"	—	—	—	—	8"
	96"	8"	20"	24"	24"	—	—	—	20"
	108"	8"	20"	24"	24"	24"	—	—	8"
	120"	8"	20"	24"	24"	24"	—	—	20"
5 Bar System	48"	8"	14"	16"	—	—	—	—	10"
	60"	8"	14"	16"	18"	—	—	—	4"
	96"	8"	14"	16"	18"	20"	—	—	20"
	108"	8"	14"	16"	18"	20"	24"	—	8"
	120"	8"	14"	16"	18"	20"	24"	—	20"
6 Bar System	48"	8"	16"	16"	—	—	—	—	8"
	60"	8"	16"	16"	16"	—	—	—	4"
	96"	8"	16"	16"	16"	16"	16"	—	8"
	108"	8"	16"	16"	16"	16"	16"	16"	4"
	120"	8"	16"	16"	16"	16"	16"	16"	16"

**Bar Spacing
4-Bar, 5-Bar and 6-Bar Systems**



BY DAYTON SUPERIOR

2400 Arthur Avenue
Elk Grove Village, IL 60007 USA
847-298-3200 • FAX 847-635-9287
www.symons.com • info@symons.com

800-800-SYMONS

Adjustable Column Form — Form square or rectangular columns efficiently with a minimum number of steel panels.

Alisply™ — Clamp-type, metric-dimension system is quickly assembled and reconfigured for fast-paced gangforming.

Aluminum Beams and Joists — Lightweight beams/ joists from 4' to 30' (122cm to 914cm) for deck or gangform applications.

Box Culvert Traveler — Rolling steel framework is compatible with Steel-Ply, Versiform and Max-A-Form systems.

Chemicals — Liquid, cement, epoxy and other specialty products for concrete construction and repair.

DeckFast™ — A quick two-component system of modular panels and shores for creating flat concrete decks.

Flex-Form® — Specially designed steel-faced system for forming curved walls and round tanks with no surface “chording”.

Form Liner — More than 100 standard patterns, in four different materials, create unique concrete textures.

FormRight™ — The advantages of a clamp-type gangform, with the handset flexibility for details. (Interchangeable with Rasto™)

FrameFast™ — Provides 24,000 lb. (106kN) load capacity per shore frame with spacings from 3' to 15' (91.4cm to 457.2cm).

Garage Beam — A complete system to form an economical, poured-in-place concrete parking garage.

Max-A-Form® — A durable, all-steel forming system that is ideal for pier caps and self-spanning applications.

Resi-Ply™ — A low cost, 1½" (2.9cm) plywood forming system for residential construction, in 4-bar, 5-bar and 6-bar spacing.

Roller Deck — Column-mounted deck support system replaces conventional shoring, providing access for other trades.

Room Tunnel — One room per day, per form provides maximum forming productivity for repetitive room designs like hotels.

ShorFast™ — High capacity aluminum leg and jack shoring system can support up to 30 kips (133kN) per leg.

Steel-Ply® — The most recognized modular system, with more than 80 panel and filler sizes, for handsetting or gangforming.

Street Smart™ — Reusable steel forms for residential curb and gutters, industrial slabs and highway paving applications.

Symons Silver™ — A lightweight aluminum system that makes residential forming operations efficient and productive.

Symons Soldier™ — The “next generation” construction beam that can be used as a brace, strongback, waler or shore.

Truss — Crane handling of large aluminum tables increases deck forming productivity for repetitive bays.

Versiform® — Steel frame/plywood face gangforming system that provides a smooth concrete finish.

Printed in U.S.A.
© 2008, Symons
Product Code 91166

