



Versiform®

Versiform® Forming System



The Versiform forming system is the solution for concrete structures when high production gang forming is required. This standard modular system, consisting of an all-steel rugged frame with a $\frac{3}{4}$ " high density plywood face, provides the durability and concrete finish needed.

Versiform isn't just for flat wall gang forming either. It's complemented by the industry's most extensive line of timesaving accessories to improve overall forming productivity.

The wide range of panel sizes and accessories means that you'll be able to form pilasters, bulkheads, corewalls, "Y" walls or battered walls easily. These are complex forming details that aren't possible with some of the other heavy-duty gang systems. Versiform is ideal for forming wastewater treatment plants, bridges, piers and other large commercial concrete structures. Added versatility means less job-building and more cost savings.



The Versiform forming system is also designed and manufactured with a consistent strength factor, a major consideration for job site safety.

The Versiform forming system combination of 3" channel crossmembers, special plywood, integral bracing, and load-bearing intercostals provides strength that's required for large contact areas and fast pour rates common in large gangformed projects.



Panel Sizes

Versiform® is available in 30 panel sizes, from 8' x 8' to 2' x 1'. This variety of panel sizes avoids the costly and time-consuming assembly of supplemental job-built components.

Variety of Sizes

There are eight panel widths: 1', 2', 2'-6", 3', 3'-6", 4', 6' and 8'. Most panel widths come in all four heights: 1', 2', 3' and 4'. These sizes can be combined efficiently to handle straight walls, battered walls, "Y" walls and other forming conditions.

The 8' x 8' panel, 64 square feet per unit, make setting and stripping particularly productive.

Rental Option

Versiform panels and components are all available for rent. There is no need to invest in a system that ties up your operating capital unless the number of forming projects requires ownership.

Quick Panel Connection

When panels are connected to build a gang, the only hardware needed is the contour-threaded Fit-Up Bolt and nut. These same bolts are also used for attaching accessories, limiting the possibility that a worker will accidentally use the wrong bolt for connections. Contour-threaded bolts resist clogging and binding from concrete, and workers move faster with a single-sized wrench, saving time and money.

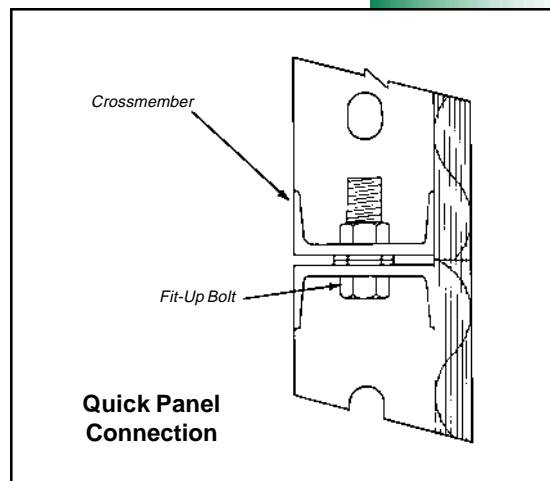
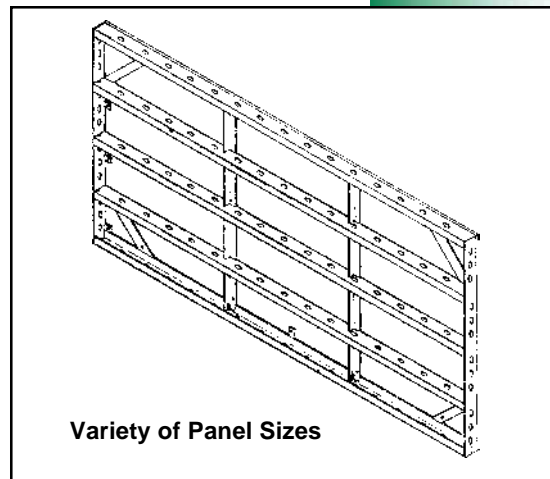
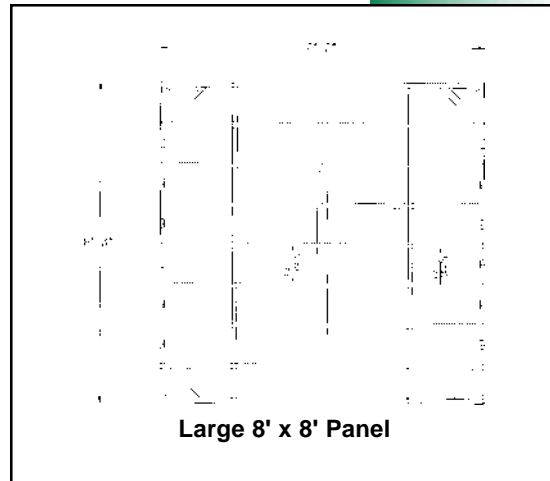

Walers

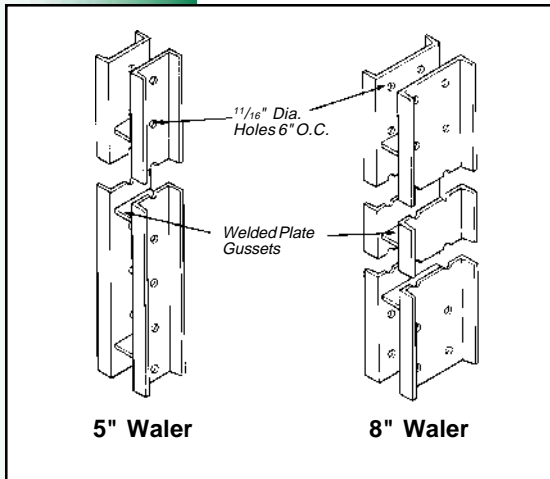

Walers transfer concrete pressures from the panel crossmembers to the wall ties. When attached vertically, the walers also align the panels and stiffen the gang. Walers permit large vertical spans between high capacity ties for maximum forming productivity.

Both 5" and 8" sizes are available in standard lengths of 4', 8', 10', 12' and 16'. The 5" walers also are available in a 6' length.

Waler Splice Channel

For applications in excess of 16', the Waler Splice provides a convenient waler connection or extension. Combining walers for different lengths often reduces the total number of walers needed on a job.

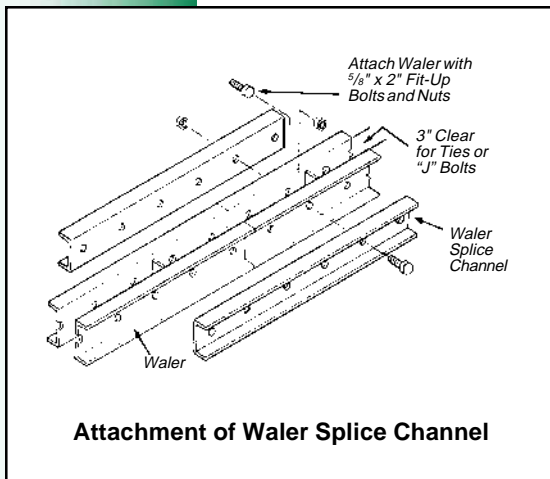

To produce a 20' gang, a splice can be used to join 8' and 12' walers, or 16' and 4' walers, or any other size combinations. The Splice Channel can be bolted on a 12' waler to make a 13' or 13'-6" waler should gang design require that particular length.

Waler Splicing on "Y" Walls

The Versiform® system also includes components that will let you form typical "Y" walls. When you use 45° Waler Splice Sets with straight Versiform walers, you'll find tremendous savings in time, materials and labor. The load-gathering strength of the walers eliminates lumber blocking and bracing, reducing the material and labor required for "Y" wall forming.

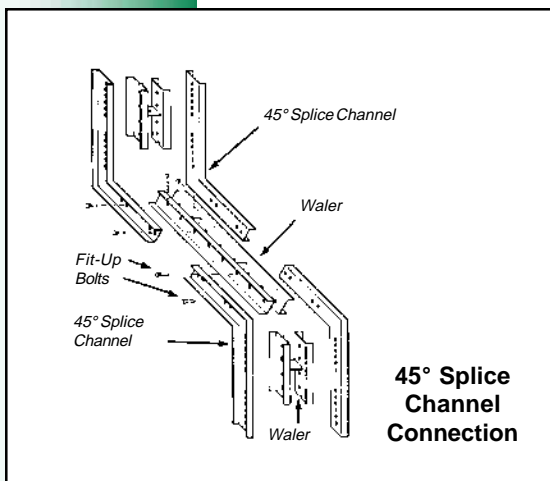

Strongbacks

Soldier Beam

The Symons Soldier Beam is a versatile, lightweight, 50 ksi steel beam. The Soldier Beam can be used in place of the 8" waler when gang weight becomes a critical factor.

Soldier Beams are available in standard lengths of 1'-6", 2', 3', 4', 8' and 12'. They can be bolted together to develop a longer, full moment beam. These beams can be used with the Versiform® system for strongbacks, bracing and one-sided concrete forming applications.

Waler Strongback

Strongbacks stiffen and align gangs horizontally. Depending on the amount of stiffness required, either the 5" or the 8" waler may be utilized as gang strongbacks and spaced to maximize tie capacities.

Waler Strongbacks are connected to each vertical waler using J-Bolts, Plate Washers and $\frac{5}{8}$ " nuts. Panel Waler Connectors should always be used to provide a safe, positive connection between the vertical waler and the horizontal waler.

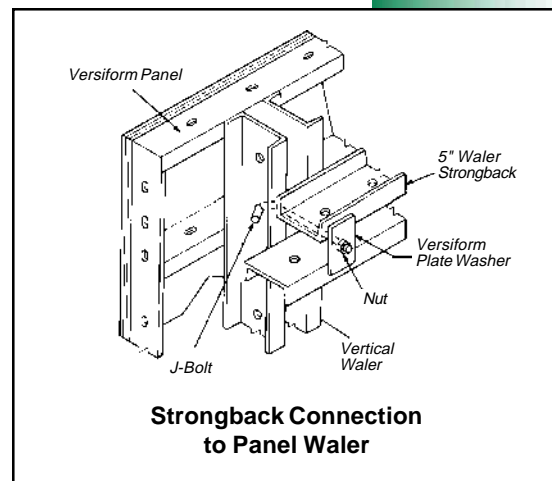
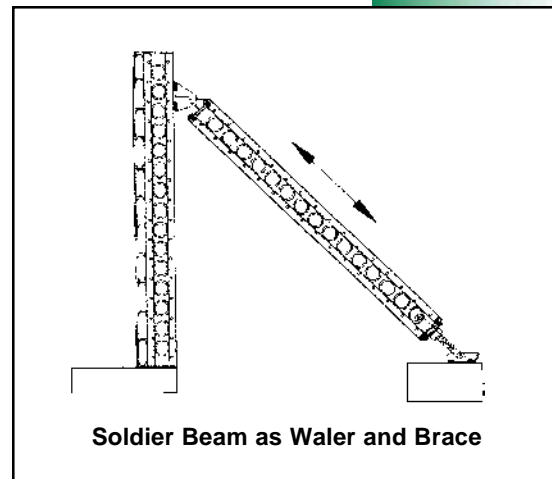

Waler Attachment Methods

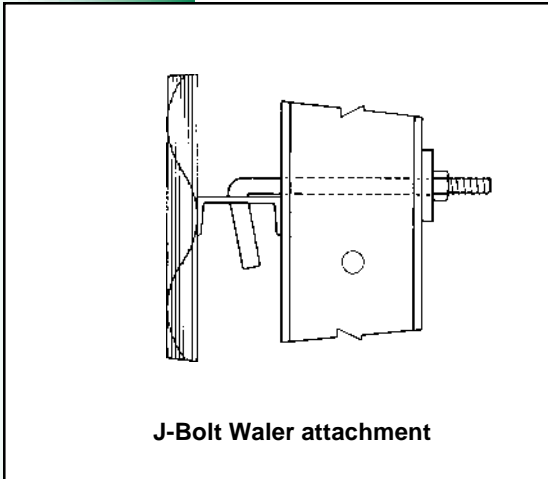

J-Bolt

The waler connections in the Versiform® forming system couldn't be easier. The contour-threaded J-Bolt is attached to the panel at 6" increments through holes in the crossmembers. Unlike systems that use intermediate connecting hardware, the Versiform connection does not require waler clips, saving labor and time.

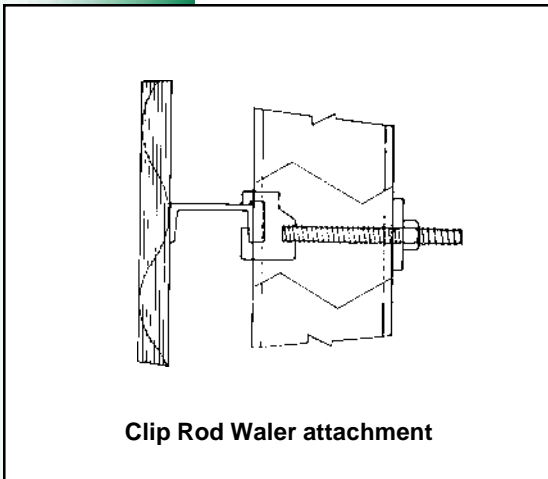

Clip Rod

To provide added flexibility in waler and tie placement, the Clip Rod can be used in forming situations where opposing panel crossmember holes do not align. The Clip Rod can be installed at any point on the channel and provide a convenient way to attach walers in corners or on other unusual details. This is a quick solution to a potential job problem.

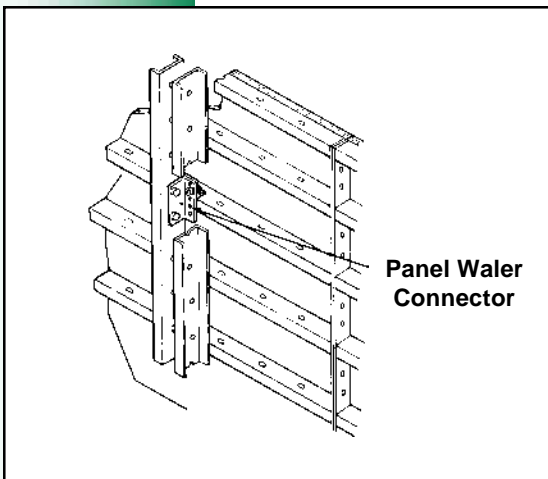

Panel Waler Connector

A simple Panel Waler Connector with Clip Angle is attached using standard fit-up bolts and nuts. This simple connection takes the place of one J-Bolt on each vertical waler and prevents the waler from "slipping" up or down on the gang. This positive connection makes the gang a safe unit when crane handling and positioning.

Gang Lifting Brackets

Gang Lift Bracket

The Gang Lift Bracket has a certified safe load rating of 2,000 lbs. It is easily attached to Versiform® panel crossmembers. The Gang Lift Bracket is attached with standard $\frac{5}{8}$ " contour threaded rod and nuts.

Gang Lift Brackets provide safe pick points for crane attachment and allow quick and efficient movement of gangs.

Note: The number and location of Gang Lift Brackets must be determined by engineering analysis. Consult a Symons Representative.

Waler Lift Bracket

The Waler Lift Bracket has a certified safe load rating of 4,000 lbs. It is attached to the Versiform waler with two $\frac{5}{8}$ " x 6" Fit-Up Bolts and $\frac{5}{8}$ " nuts.

Waler Connector

The Waler Connector has a certified safe load of 2000 lbs. A minimum of two Waler Connectors are required for each Waler Lift Bracket.

The upper Waler Connector is located under the double crossmembers of two Versiform panels. The lower Waler Connector is located at approximately the mid-depth of the gang under the double crossmember of two Versiform system panels.

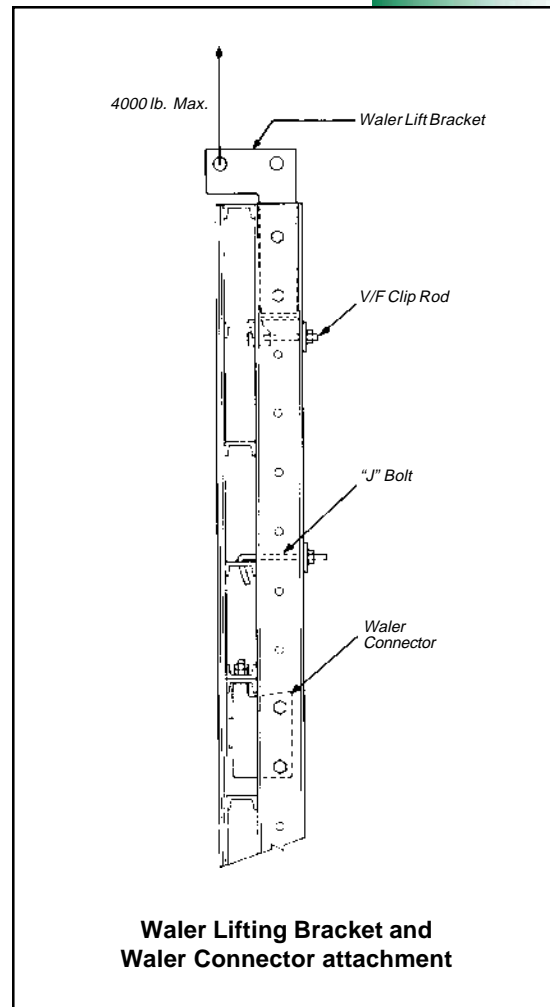
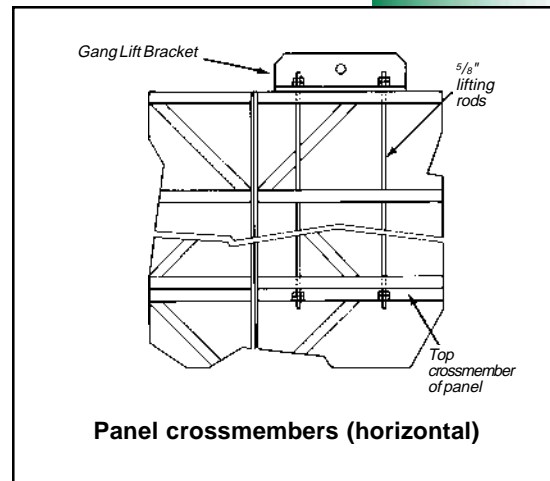

Taper Ties and She-Bolts



She-Bolts

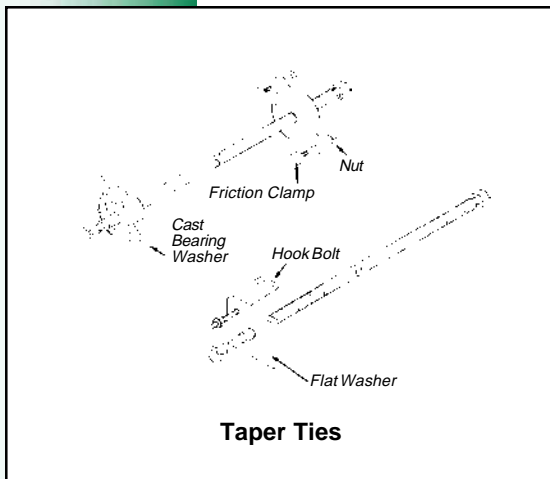

Taper Ties

Symons offers the industry's largest line of Heavy Duty ties and hardware to complement the Versiform® forming system.

When 5" walers are used, Symons supplies 50 Kip She-Bolts with $\frac{7}{8}$ " diameter inner units, or Taper Ties. The strength of these ties combined with the load-gathering ability of the Versiform panels and walers permits 4' x 4' or greater tie spacing in most gang-form applications.

Using fewer ties with each Versiform gang reduces overall labor and material costs. Fewer ties often means less obstruction for the embedments, penetrations and blockouts in typical concrete walls.

To reduce labor even more, 85 Kip She-Bolts with $1\frac{1}{8}$ " diameter inner units, and 96 Kip Taper Ties are supplied for use with Versiform gangs using 8" walers. These tie systems are standard products in the Versiform product line.

Tie Systems Load Limits		
Components	Tie Type	Ultimate load (lbs.)
5" walers and standard ties	She-Bolt Tie	50,000
	Taper Tie	50,000
8" walers and heavy-duty ties	She-Bolt Tie	85,000
	Taper Tie	96,000

Tie Hardware and Accessories

Adjustable Top Tie

Small items can play a big part in making a gang form productive and easy to use. Versiform® offers many standard accessory products that are considered custom components in other systems.

The Adjustable Top Tie assembly, a real time and money saver, connects opposing Walers and simultaneously functions as a spreader and a tie. All components are above the concrete, making the entire assembly reusable.

Spreader Clip

The Spreader Clip is used with 50 Kip Taper Ties or She-Bolts. It is a U-shaped plate that fits over the Cast Bearing Washer and nut, preventing inward movement of the formwork. A tie with spreader clips near the bottom of the gang and one near the top of the gang will maintain the desired wall thickness before concrete placement begins.

Batter Plate Washer

In the Versiform forming system, tying is easily accomplished in forming applications where opposing walers are out of parallel or in battered wall applications. The slotted opening in the batter plate casting accepts ties that intersect the walers at any angle from 74° to 106°. This eliminates labor intensive shimming operations.

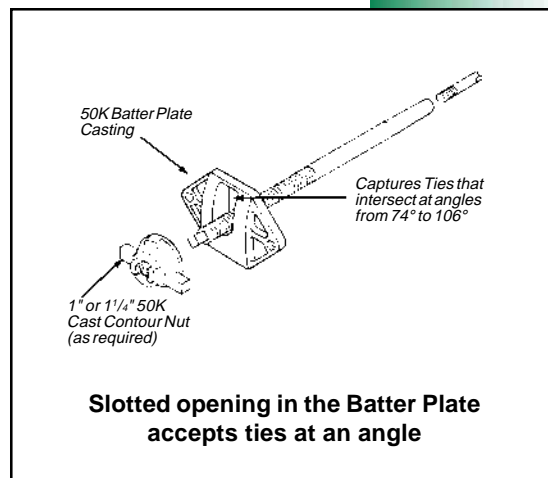
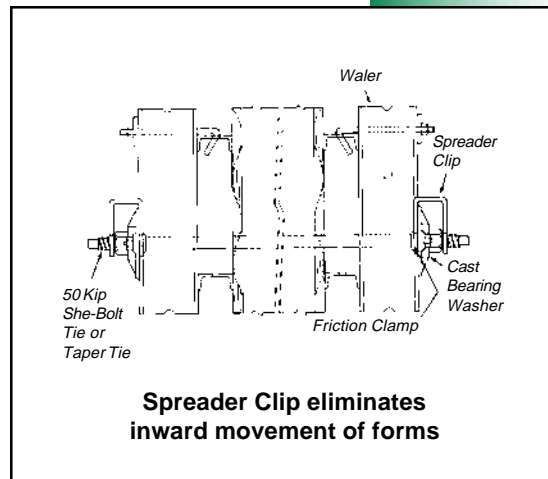
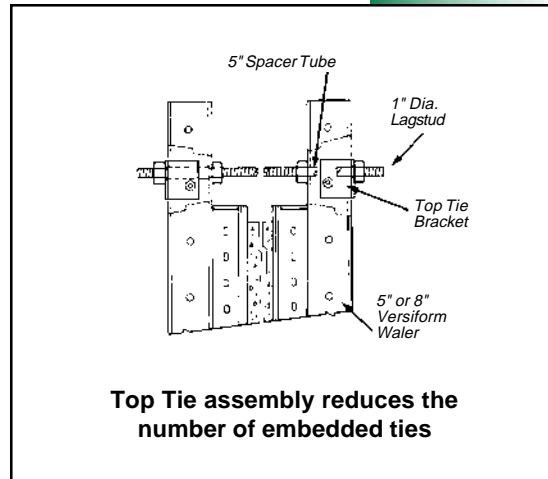

Corner Options

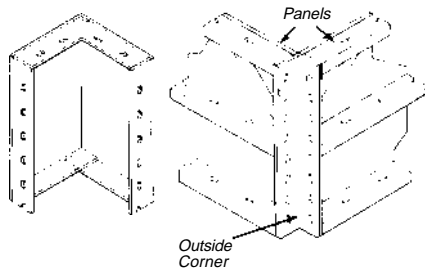

90° corners easily produced with standard panels plus Inside and Outside Corners

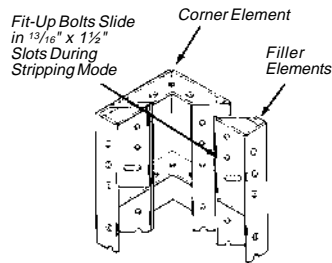

Three-piece Inside Stripping Corner assembly

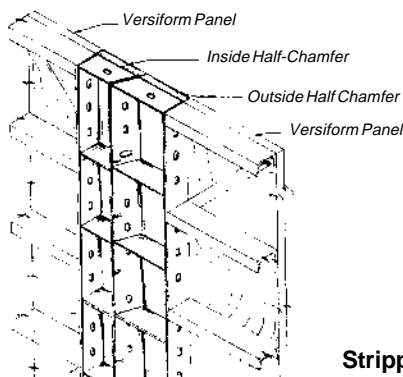

Stripping Panel

Rigid Corner

These components are available in 2', 4' and 8' lengths and are connected using the same $\frac{5}{8}$ " Fit-Up Bolts and nuts used throughout the system. Rigid Corners keep formwork square at corners with a minimum of labor

Inside Stripping Corner

The three-piece Inside Stripping Corner elements disconnect and slide inward to simplify stripping without any gang disassembly. Versiform® gangforms with this assembly are never "trapped" in a corner after a concrete placement is completed.

Stripping Panel

The beveled side rails on the Stripping Panels are especially valuable in gangforming where there are intersecting walls, pilasters or corners. Gangs assembled with these components are easily stripped, eliminating the labor for disassembly of Versiform gang sections.

Two Inside Half Chamfers can be bolted together to form a 135° Inside Corner. Two Outside Half Chamfers can be bolted together to form a 135° Outside Corner. This maximizes inventory utilization and saves the cost of additional special forms.

Walkway Bracket

The Walkway Bracket assembly provides a certified safe working load of 750 lbs. When combined with lumber planking, toeboards and rails, it provides a work platform in compliance with OSHA standards and safe worker access for pouring.

Attach the walkway assembly to the vertical walers or the panel crossmembers with standard Fit-Up Bolts and nuts.

Pipe Form Aligner

To ensure that the gangs are straight and plumb, attach the steel Pipe Form Aligners to one side of the gang. The assembly includes a shoe for anchoring, an adapter to bolt the top end of the aligner to panel siderails or walers, and an integral turnbuckle and telescoping adjustment that permits aligner lengths from 13'-9" to 19'-9".

Pipe Form Aligners provide an efficient method of wall alignment that saves time and eliminates wood bracing and waste.

Safety Eye Angle

The installation of Safety Eye Angles on Versiform® panels allows easy attachment of personal fall protection equipment while working on forms. Although the installation of work platforms is recommended and normally provides a more efficient work method, the Safety Eye Angle can be an important option for certain forming conditions where fall protection is needed.

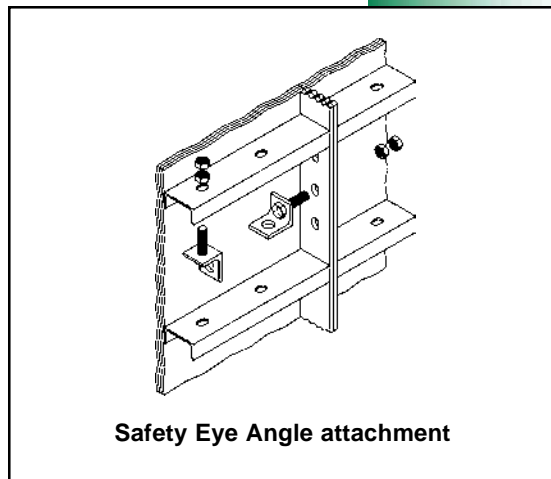

Columns



Columns can be easily produced by joining standard Versiform® panels and Outside Corners with $\frac{5}{8}$ " Fit-Up Bolts and nuts. The strength of the Versiform panel design permits columns up to 4' wide to be poured without ties.

Column Hinge

Using Column Hinges instead of a rigid Outside Corner lets you use ganged column forms to quickly set and strip multiple columns. Like most components of the Versiform forming system, the hinges bolts on with standard hardware.

Outside "L" Corner

The Outside "L" Corner is primarily used to form columns. Available in 2" x 2", 3" x 3" and 4" x 4" face dimensions, they have lengths of 4', 6' and 8'.

Forming columns of different or changing dimensions is easy because no additional ties are required at the corner connection. This reduces labor and the associated costs.

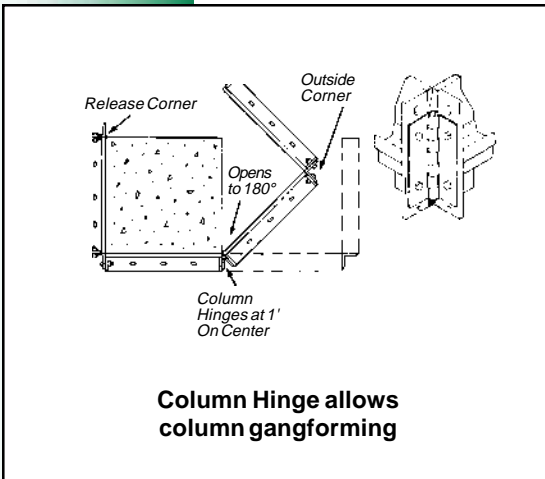

Column Hinge allows column gangforming

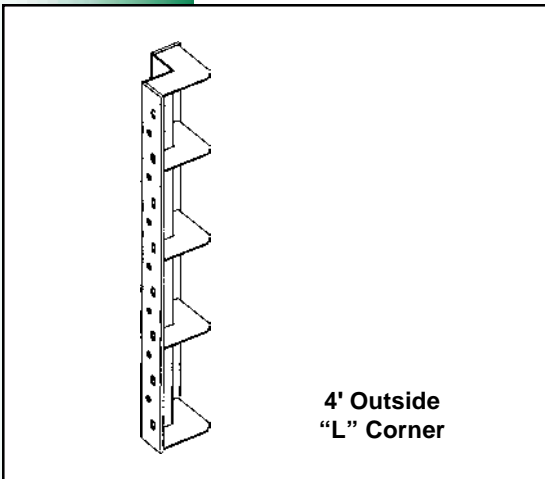

4' Outside "L" Corner

Special Forming

Sky-Lift™

Sky-Lift is an engineered jump form system designed for use on external elevated concrete forming applications.

Versiform® walers are connected to the Sky-Lift Screw Jack Assembly, an integral part of the Sky-Lift System. The Sky-Lift assembly is supported from Jump Shoes bolted to inserts in the previous concrete lift. These features, combined with the 8' wide working platform, allow for stripping and cleaning. All gangform preparations proceed without a crane.

One-sided Wall Forming

Standard 5" or 8" walers allow one-sided forming when used in conjunction with Diagonal Brackets, a Corner Bracket, a Shear Plate, a Bearing Wedge and anchors.

The wall height and/or concrete pressure determines whether the 5" or 8" walers needs to be used. The 5" walers are used for wall heights up to 10', and the 8" walers are used for wall heights up to 12'.

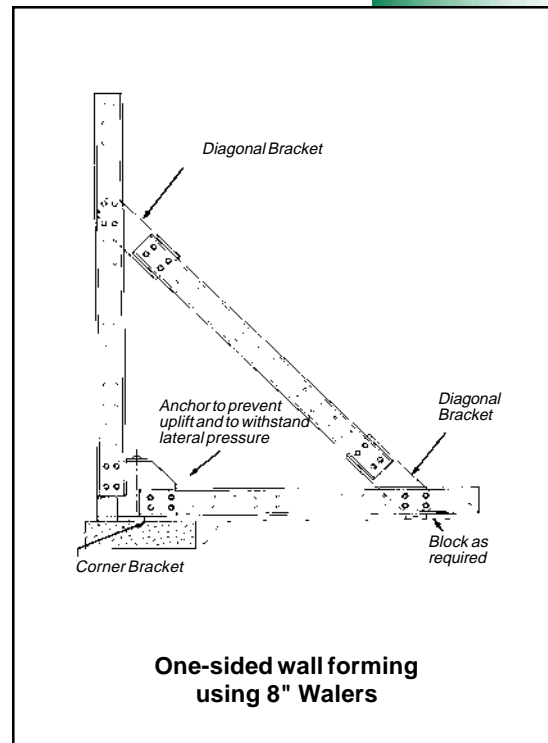
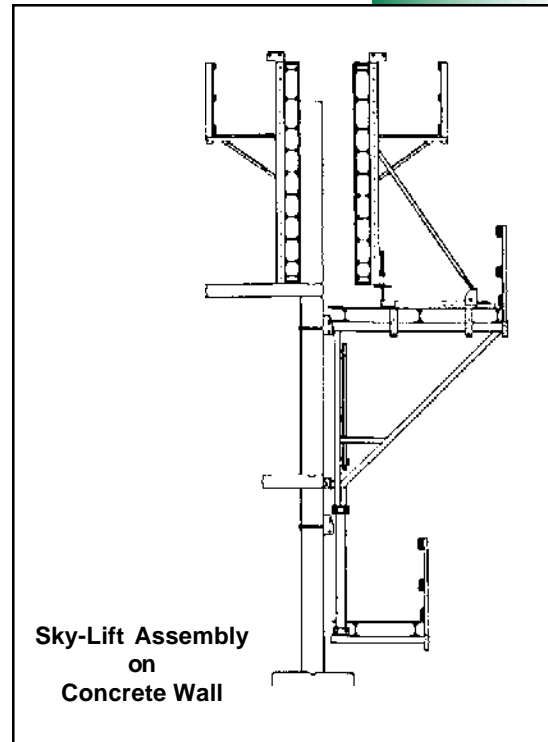

Corewalls

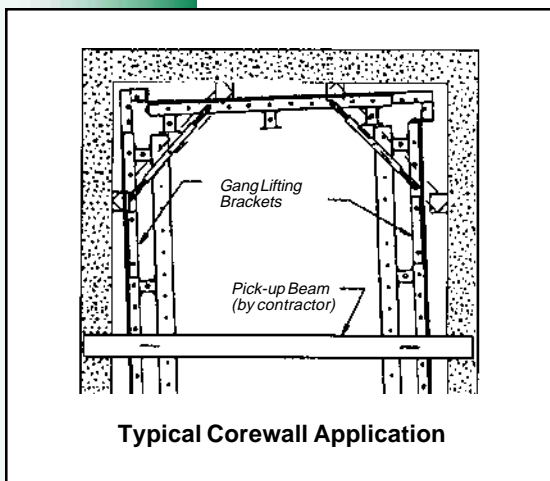
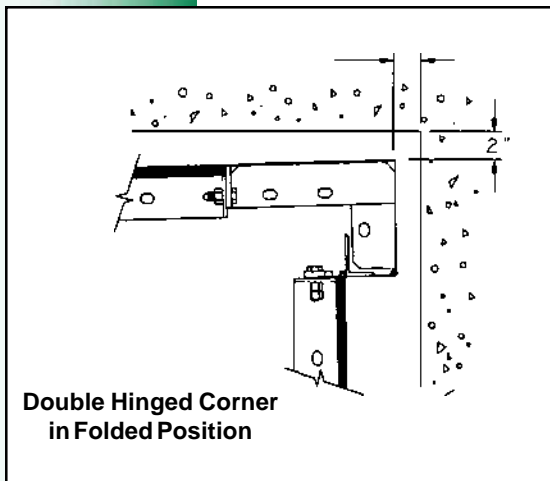
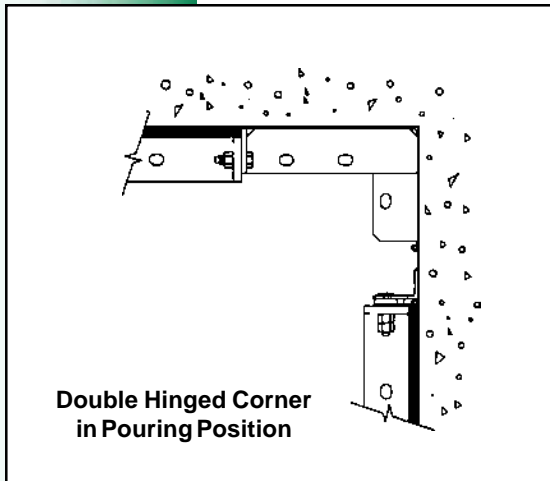

The Double Hinged Corner provides Versi-form® with the flexibility needed to efficiently gangform corewalls.

As the Double Hinge Corners hinge to the folded position, the corners draw inward 2" from each wall face. This reduces the overall corner-to-corner length of each gang by 4". With all corners fully retracted, the coreform retains the structural advantages of a rigid box, but allows for stripping.

The coreform is then positioned onto the Adjustable Shear Wall Bracket and support falsework previously installed for the next pour. Costly crane time is minimized because expanding the Double Hinge Corners back to full coreform pour position can be accomplished after the crane is released.

The Versiform forming system can handle most gangforming challenges you'll encounter, but there's even greater versatility possible when combined with other forming systems.

Transition Corner

The Transition Outside Corner allows Versiform to be used with Steel-Ply or Max-A-Form® for bulkheads, columns and other details where forming design flexibility is needed. One leg of the Outside Corner Angle connects to Versiform or Max-A-Form with standard $\frac{5}{8}$ " x 2" Fit-up Bolts and Nuts. The opposite leg connects to Steel-Ply with standard Wedge Bolts.

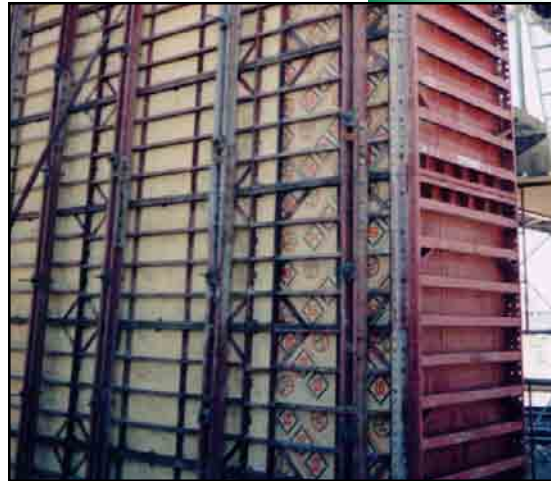

Transition Filler

A Transition Filler allows the use of standard Steel-Ply panels and fillers for details or small cut-up areas. Standard Transition Fillers are available in 6" widths and 2', 4', and 8' lengths.

Filler Angle

In gangs where a dimension up to 12" is required, a Filler Angle with $\frac{3}{4}$ " plywood can be used without additional support. Filler Angles are offered in 2', 4', and 8' lengths.

Filler Angles are an ideal substitute for panels when encountering rebar or other penetrations in the concrete wall.

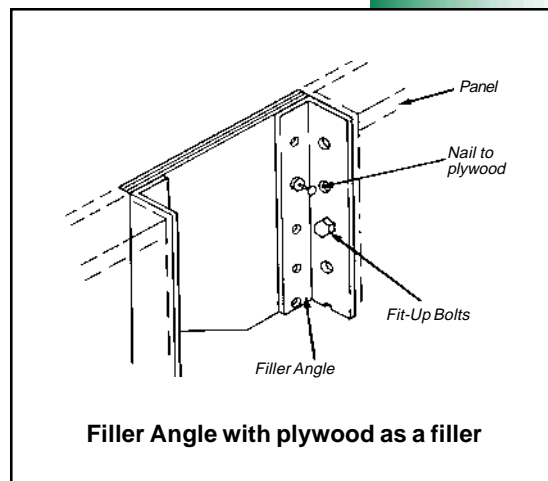
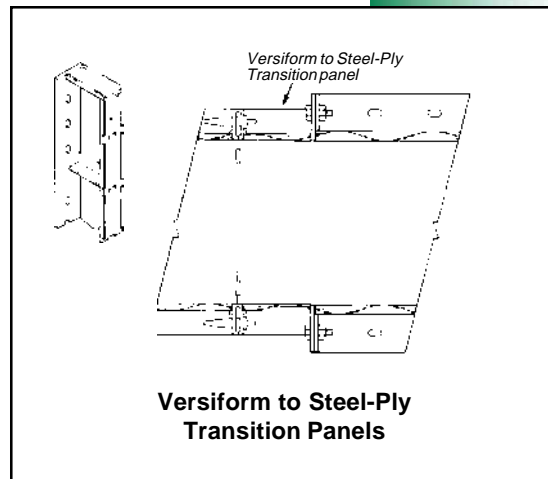

Adjustable Column Form — Form square or rectangular columns efficiently with a minimum number of steel panels.

Alisply™ — Clamp-type metric dimension system is quickly assembled and reconfigured for fast-paced gangforming.

Aluminum Beams and Joists — Lightweight beams/ joists from 4' to 30' (122cm to 914cm) for deck or gangform applications.

Box Culvert Traveler — Rolling steel framework is compatible with Steel-Ply, Versiform and Max-A-Form systems.

Chemicals — Liquid, cement and epoxy products for concrete construction and repair.

Flex-Form® — Specially designed steel-faced system for forming curved walls and round tanks with no surface "chording".

Form Liner — More than 30 standard patterns, in four different materials, create unique concrete textures.

FrameFast™ — Provide 24,000 lb. (106kN) load capacity per shore frame with spacings from 3' to 15' (91.4cm to 457.2cm).

Garage Beam System — A complete system provides an economical, poured-in-place concrete parking garage.

Max-A-Form® — A durable, all-steel forming system that requires no walers. Ideal for pier caps and self-spanning applications.

Resi-Ply™ — A low cost, 1¹/₈" (2.9cm) plywood forming system for residential construction. Available in 4-bar, 5-bar and 6-bar.

Roller Deck — Column mounted deck support system replaces conventional shoring, providing access for other trades.

ShorFast™ — Aluminum leg and jack shoring system can support up to 30kips (133kN) per leg.

Steel-Ply® — The most popular modular system with more than 80 panel and filler sizes for handset or gangforming.

Symons Soldier™ — The "next generation" construction beam that can be used as a brace, strongback, waler or shore.

Street Smart™ — Reusable steel forms for residential curb and gutters, industrial slabs and highway paving applications.

Symons Silver™ — A lightweight aluminum system that makes residential forming operations very efficient and productive.

Versiform® — Steel frame/plywood face gangforming system that provides a smooth concrete finish.

 **SYMONS**
200 E. Touhy Avenue
Des Plaines, IL 60018 USA
847-298-3200 • FAX 847-635-9287
www.symons.com • info@symons.com

Call 800-800-SYMONS

