

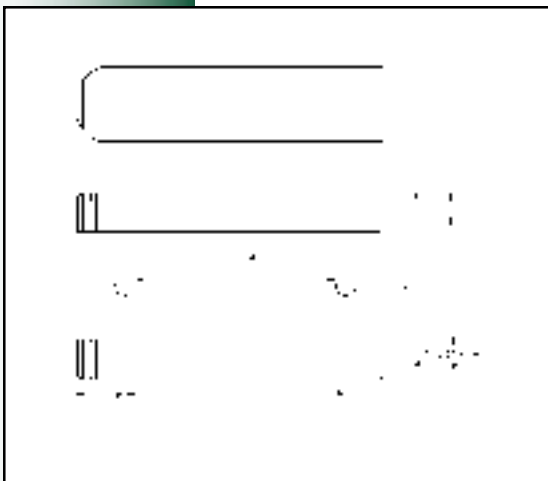

Wood Beam

formerly H20 Wood Beam

System Design

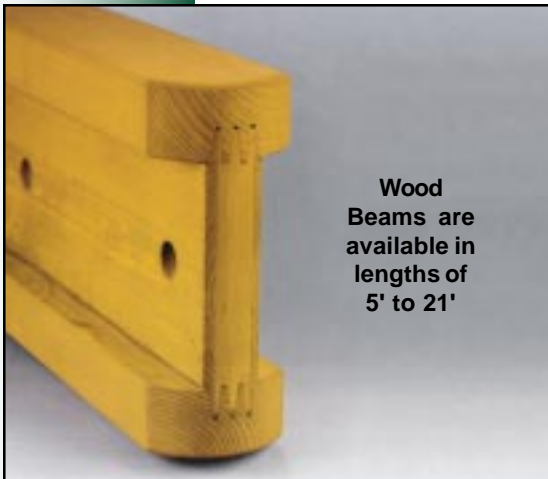
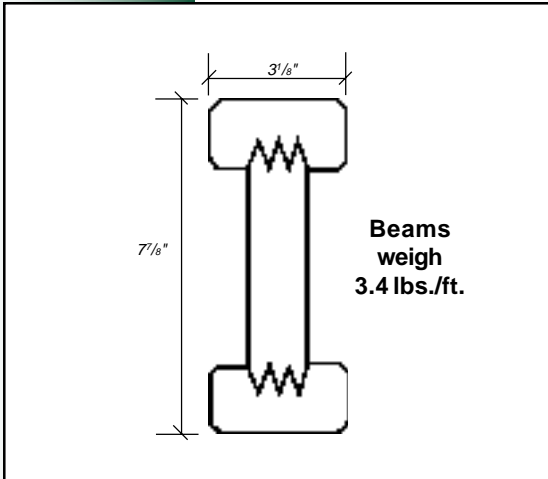

Wood Beam Design

Wood Beams are the structural elements that provide long span, light-weight support. With capacities comparable to 6½" aluminum joists, but considerably less costly, these beams are an excellent option for many concrete forming and shoring applications.

Wall Forming

Wood Beams create high capacity wall forms with maximum versatility in tie spacing. Allowable form pressure from 1000psf to over 2000psf can be achieved with proper plywood, beam spacing, walers and ties.

Elevated Deck Support

The Wood Beam deck support system consists of post shores and tripods with Wood Beam utilized as both joists and stringers. Wood Beams can also be utilized as stringers when supported with the FrameFast steel shoring system or the ShorFast aluminum shoring system.

Beam Sides

Beam sides are quickly formed with plywood, Wood Beams and Beamside Form Bases. The Wood Beam provides an excellent nailing surface on all 4 sides to accommodate almost any configuration.

Components for Wall Forming

Walers and Waler Connectors produce a pressure- and tension-resistant element connection that is tight, flush, and in true alignment.

Joining Wedges are used with waler, corner connectors, hinged connectors, outer corner bearings and tension straps.

Lumber Beam Clamps connect the Wood Beam to the waler at any required position.

Components for Deck Support

Post Shores provide support for stringers. The 350 Post Shores adjust from 6'6" to 11'5", and the 550 Post Shores adjust from 10'1" - 18' nominal. The inner tube diameter is 2½" nom., and the outer tube is 3" nom. for both shores.

2-Way Fork Heads retain one or two stringer ends, depending on which way the head the head is positioned.

Intermediate Support Heads are utilized when additional post shore support is required within the stringer span.

Tripods stabilize post shores to aid in erection assembly. The hinged design allows the legs to be adjusted to 90°, 180° or full 360° positions to accommodate placements near walls and in corners.

Assembly Forks make placement and removal of overhead Wood Beams easier by extending worker reach for lifting the beams in and out of the Fork Heads.

Components for Beam Sides

Beam Side Form Bases are fastened to the Wood Beam flanges at beam locations.

Adjustable Beam Side Forms connect to Bases to create the required beam height. The attached bolt slips into holes for incremental adjustments and is secured with a cotter pin.

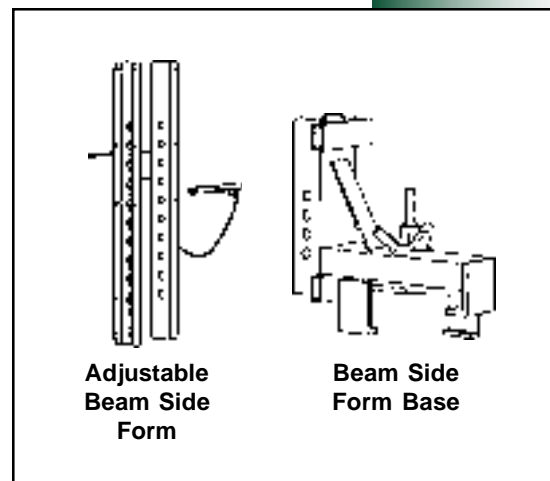
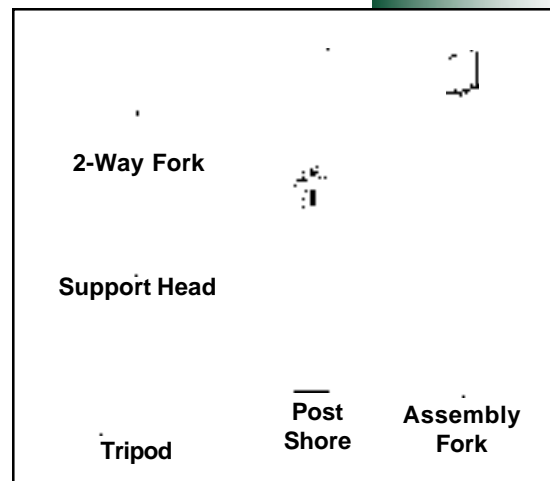
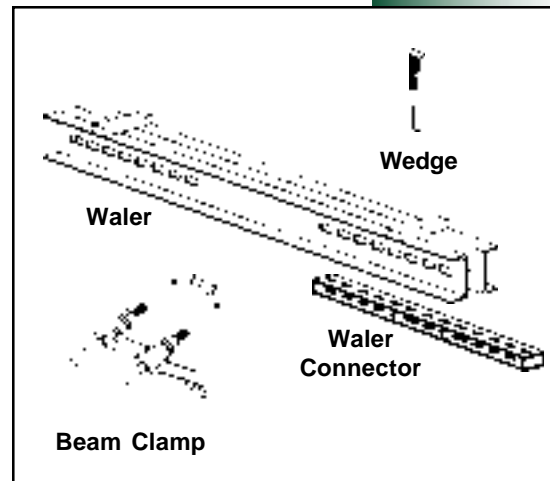

Wall Forming

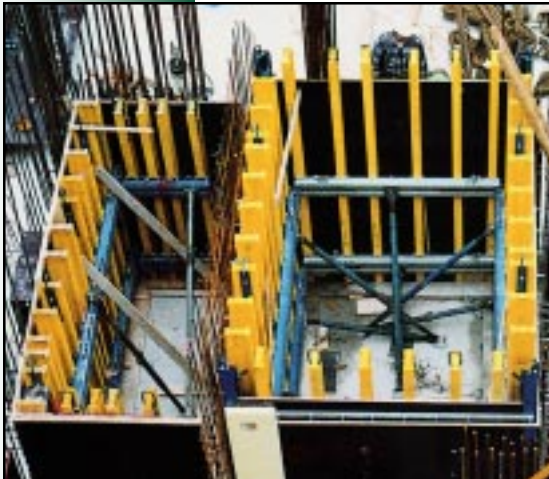

System Flexibility

Wood Beam waler spacings and tie locations can be adapted to specific forming requirements for maximum versatility. Convenient placing of these components speeds assembly. This makes the Wood Beam gang forming system easy to assemble, position and align. The long length of the beam, in combination with steel walers, maximizes the tie spacing and square footage of forming contact area.

Contractors appreciate the complete line of components and accessories to handle virtually any forming situation. With a wide range of concrete construction products, Symons can provide solutions for bulkheads, pilasters, corners, battered walls, core walls, curved walls, multiple lifts, top ties and walkways. Hardware and Accessories

Walers, aligners and lifting brackets combine to produce simple, yet efficient Wood Beam gang forms.

Positive Connections between beams and aligners are made quickly with Lumber Beam Clamps.

The Wood Beam system can be utilized to form core walls, columns and other common design elements much the same way as aluminum beams and other conventional systems. This light weight, economical option provides more opportunities for contractors to utilize their Wood Beams in more ways.

Lifting Brackets, walers, aligners and other hardware and accessories complete the vertical forming system.



Deck Support



Post Shore System

Shoring heights from 8' to 19'-4" are achieved with high-strength 350 and 550 Post Shores.

A variety of post shore heads are available to accommodate single or double wood beam combinations used as stringers.

Galvanized tripods hold post shores during erection. The legs may be positioned for use along flat walls or in tight corners.

Components are rust-resistant, galvanized steel for extra long life. Posts feature a Quick Release Pin for fast stripping.

Instead of post shores, contractors may choose to use shoring frames.

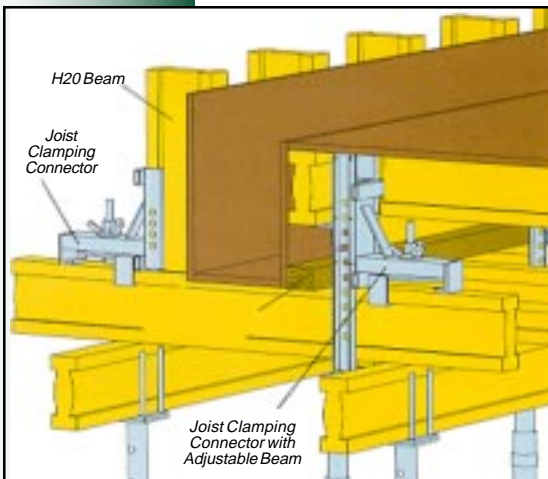

Beam Side System

Beam Side Brackets are uniquely designed to integrate beam sides and soffit into a single forming element without ties. They adjust to create most typical concrete beam depths and allow easy integration of spandrel and internal beams with concrete decks.

DeckFast™ Compatibility

The Wood Beam system offers compatibility with the DeckFast slab support system. The two systems conveniently utilize the same 350 and 550 Post Shores with Tripods. The two systems can be used in combination to allow the contractor to select the most efficient design layout for everything from residential to heavy commercial deck forming.



FrameFast™ and ShorFast™ Compatibility

The Wood Beam can be used as joists with FrameFast steel frame or ShorFast aluminum shoring when shoring heights over 19'4" are required.

Set-Up Procedures

Form set-up is fast and easy with repetitive procedures and few components.

- ◆ Set the posts at the proper locations.
- ◆ Attach tripods to stabilize the post shores.
- ◆ Place stringers into position.
- ◆ Place the joist beams from below.
- ◆ Place the deck plywood.

Stripping Procedures

- ◆ Strike the Quick Release Pin to relieve form pressure on the system.
- ◆ Turn down the Post Shore Collar two complete turns.
- ◆ Lift out beams to remove plywood and post shores.

Quick Release Pin

All Post Shores are equipped with the patented Quick-Release Pin. With the blow of a hammer, the upper portion of the shore drops slightly to relieve the slab load on the adjusting nut. The handle turns to adjust the post height for easy removal.

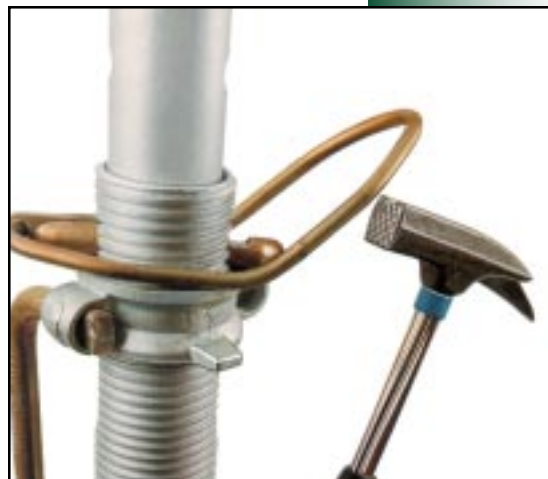
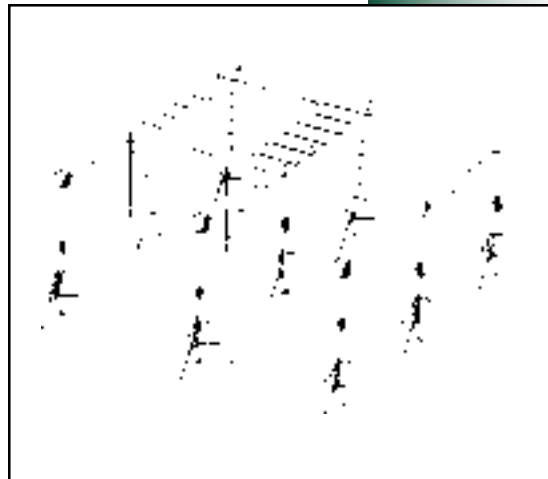
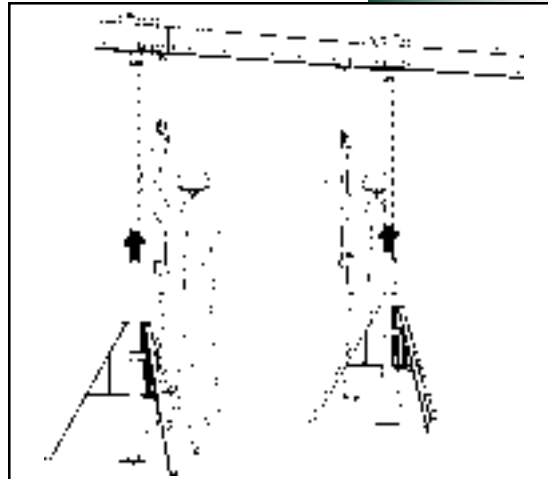

Adjustable Column Form — Form square or rectangular columns efficiently with a minimum number of steel panels.

Alisply™ — Clamp-type, metric-dimension system is quickly assembled and reconfigured for fast-paced gangforming.

Aluminum Beams and Joists — Lightweight beams/ joists from 4' to 30' (122cm to 914cm) for deck or gangform applications.

Box Culvert Traveler — Rolling steel framework is compatible with Steel-Ply, Versiform and Max-A-Form systems.

Chemicals — Liquid, cement, epoxy and other specialty products for concrete construction and repair.

DeckFast™ — A quick two-component system of modular panels and shores for creating flat concrete decks.

Flex-Form® — Specially designed steel-faced system for forming curved walls and round tanks with no surface "chording".

Form Liner — More than 100 standard patterns, in four different materials, create unique concrete textures.

FrameFast™ — Provides 24,000 lb. (106kN) load capacity per shore frame with spacings from 3' to 15' (91.4cm to 457.2cm).

Garage Beam — A complete system to form an economical, poured-in-place concrete parking garage.

Max-A-Form® — A durable, all-steel forming system that is ideal for pier caps and self-spanning applications.

Rasto™ — The advantages of a clamp-type gangform, with the handset flexibility for details.

Resi-Ply™ — A low cost, 1 $\frac{1}{8}$ " (2.9cm) plywood forming system for residential construction, in 4-bar, 5-bar and 6-bar spacing.

Roller Deck — Column-mounted deck support system replaces conventional shoring, providing access for other trades.

ShorFast™ — High capacity aluminum leg and jack shoring system can support up to 30 kips (133kN) per leg.

Steel-Ply® — The most recognized modular system, with more than 80 panel and filler sizes, for handsetting or gangforming.

Symons Soldier™ — The "next generation" construction beam that can be used as a brace, strongback, waler or shore.

Street Smart™ — Reusable steel forms for residential curb and gutters, industrial slabs and highway paving applications.

Symons Silver™ — A lightweight aluminum system that makes residential forming operations efficient and productive.

Versiform® — Steel frame/plywood face gangforming system that provides a smooth concrete finish.



A Dayton Superior Company

SYMONS CORPORATION
200 E. Touhy Avenue
Des Plaines, IL 60018 USA
847-298-3200 • FAX 847-635-9287
www.symons.com • info@symons.com

Call 800-800-SYMONS

